

Peak Auto, The EV Transition, And The Simulation Revolution

by John McElroy

AUTOLINE

The Greatest Change In Automotive History

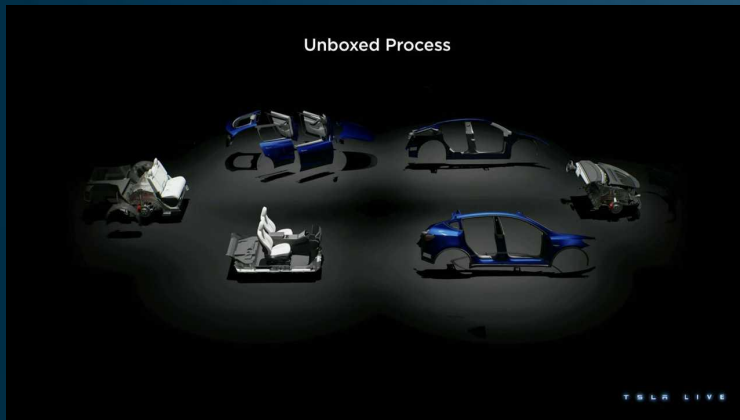

WHAT'S REALLY HAPPENING WITH EVS?

U.S. EV SALES

2020	257,872	
2021	488,397	+89%
2022	809,739	+65%
2023	1,189,057	+46%

Source: Kelly Blue Book

2024: 1.6-1.7 M +33-41%

WHAT'S REALLY HAPPENING WITH EVS?

EU EV SALES

2020	543,235	
2021	962,264	+77%
2022	1,254,305	+30%
2023	1,489,812	+18%

Source: EU-EVS.COM

2024 Q1	258,426	-47%
---------	---------	------

WE'VE HIT PEAK AUTO

	Japan	US	EU	World
2014	5,562,887	16,437,000	12,551,204	71,366,419
2015	5,046,511	17,386,047	13,713,526	72,810,898
2016	4,146,459	17,465,020	14,641,415	77,343,587
2017	4,386,378	17,134,733	15,137,732	79,881,985
2018	4,391,160	17,215,163	15,158,874	78,794,917
2019	4,301,091	17,108,156	15,340,188	74,935,731
2020	4,598,615	14,463,935	9,942,509	63,404,618
2021	4,448,340	14,926,933	11,239,741	66,211,495
2022	4,201,321	13,734,203	9,255,926	66,202,651
2023	4,779,086	15,490,000	10,500,000	72,457,199
Source	JAMA	NADA	ACEA	ACEA

WE'VE HIT PEAK AUTO

% of Americans Buying New Cars

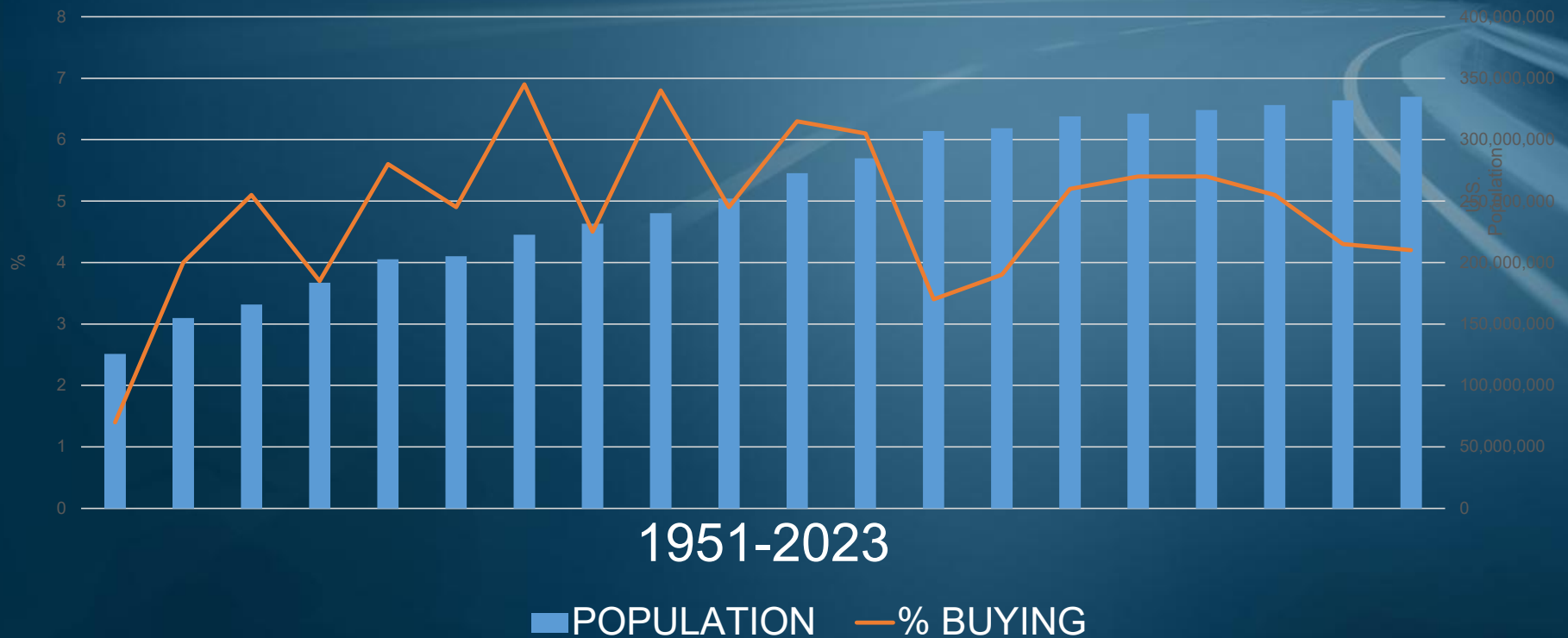

THE AMAZING, SHRINKING AUTOMAKERS

Ford Revenue Adjusted for Inflation 2014-2023

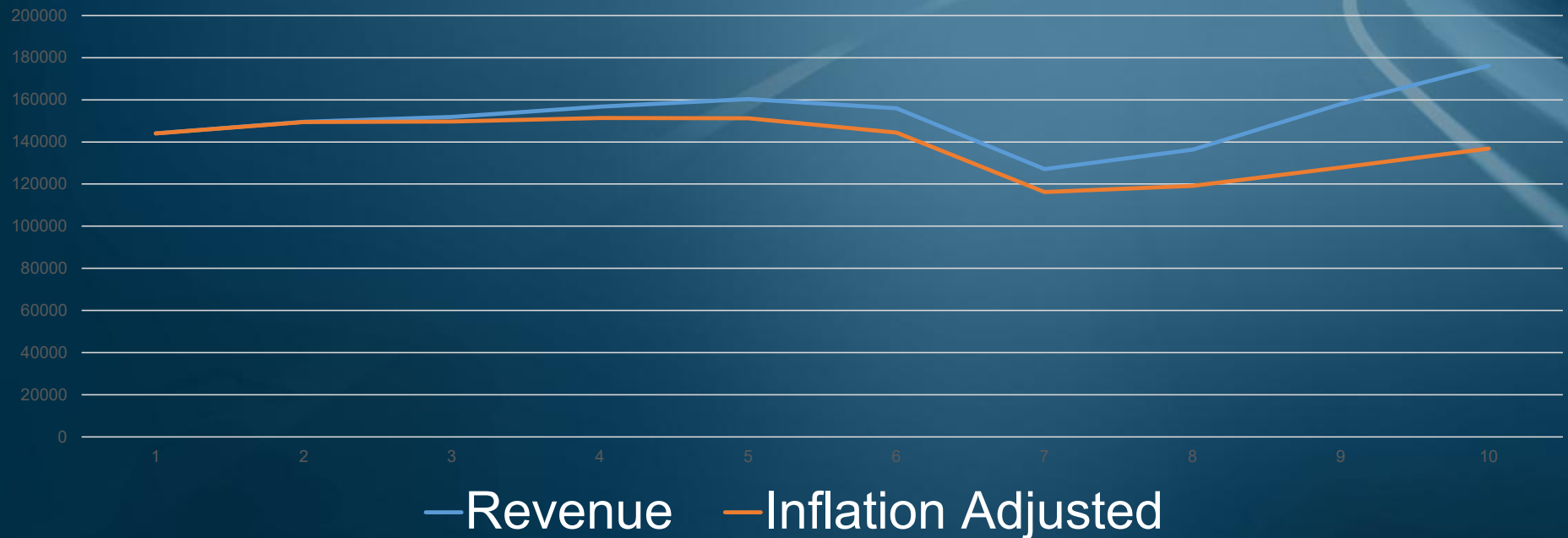

THE AMAZING, SHRINKING AUTOMAKERS

GM REVENUE ADJUSTED FOR INFLATION 2014-2023

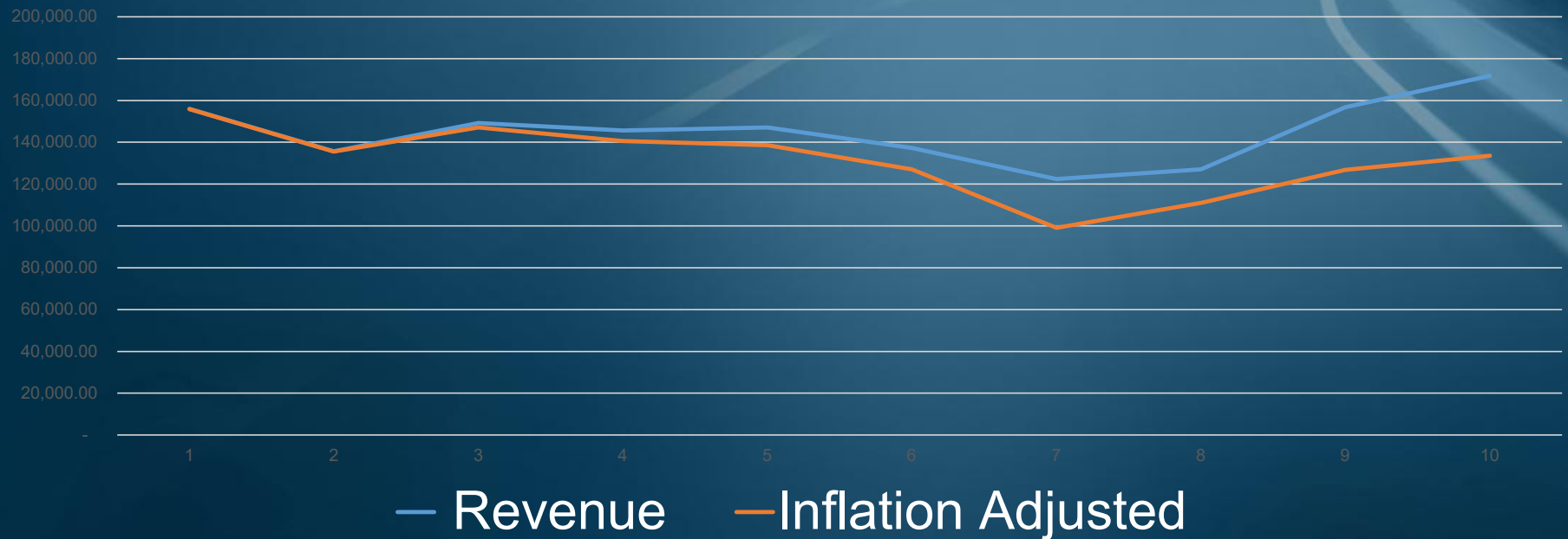

HERE COME THE CHINESE!



The Old Way Of Designing Cars



Tape Drawings



Interior Bucks

THE NEW WAY OF DESIGNING CARS

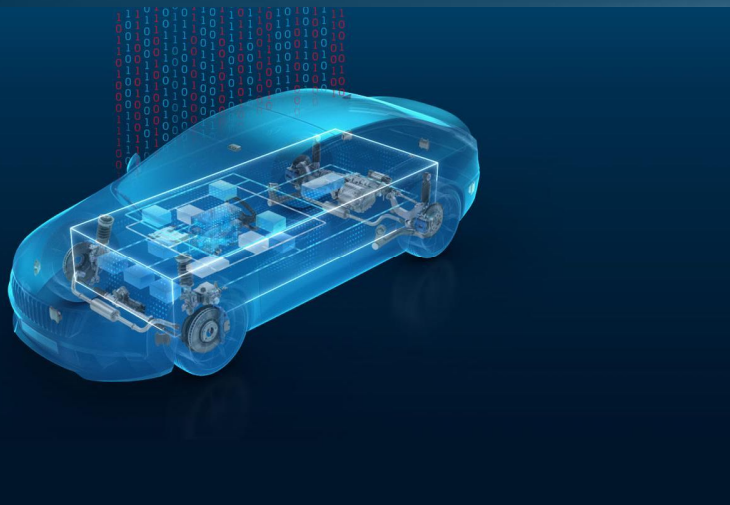

Software Defined Vehicles

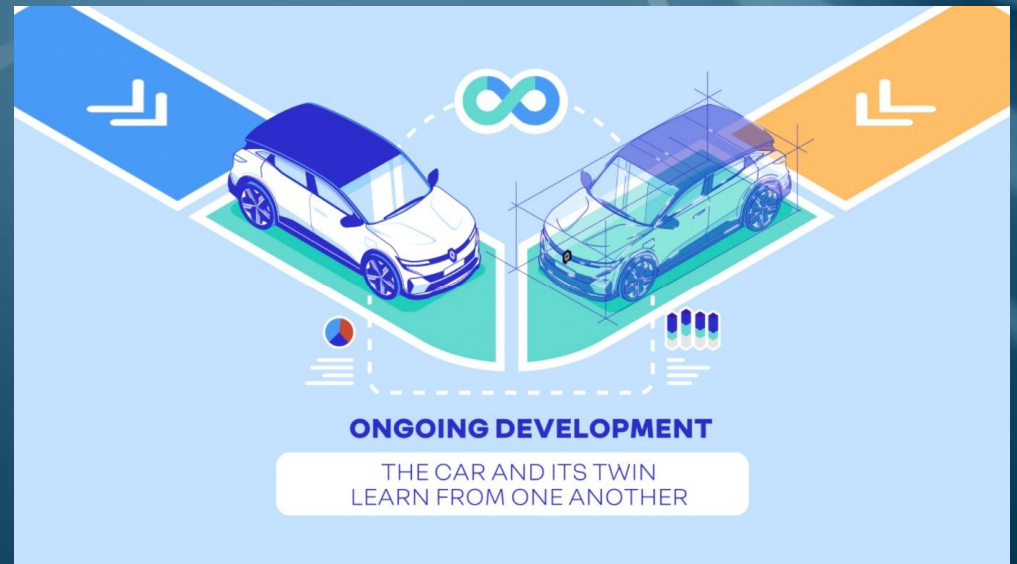

Digital Twins

DIGITAL TWINS ARE TAKING OVER

Toyota-style digital monozukuri

TOYOTA
MONOZUKURI
WORKSHOP
2023

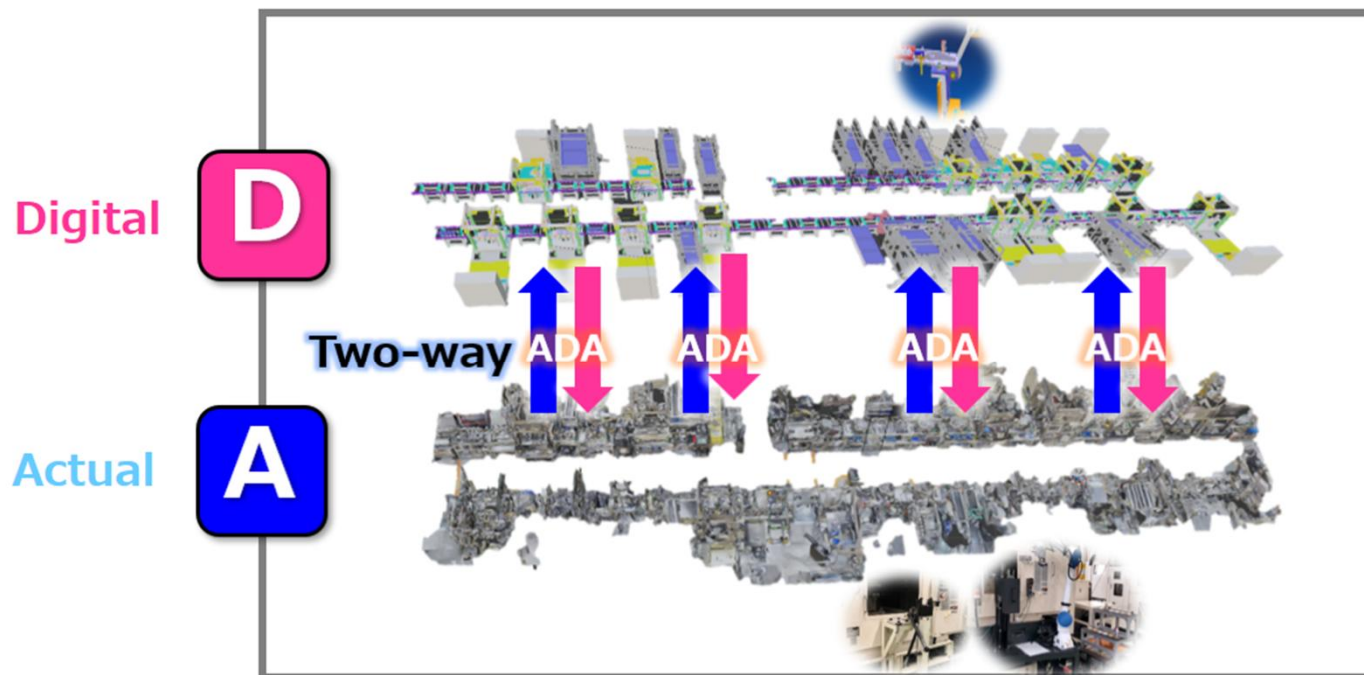

Continuously improving genba competitiveness
with two-directional digital twins

Radical Approach To Manufacturing

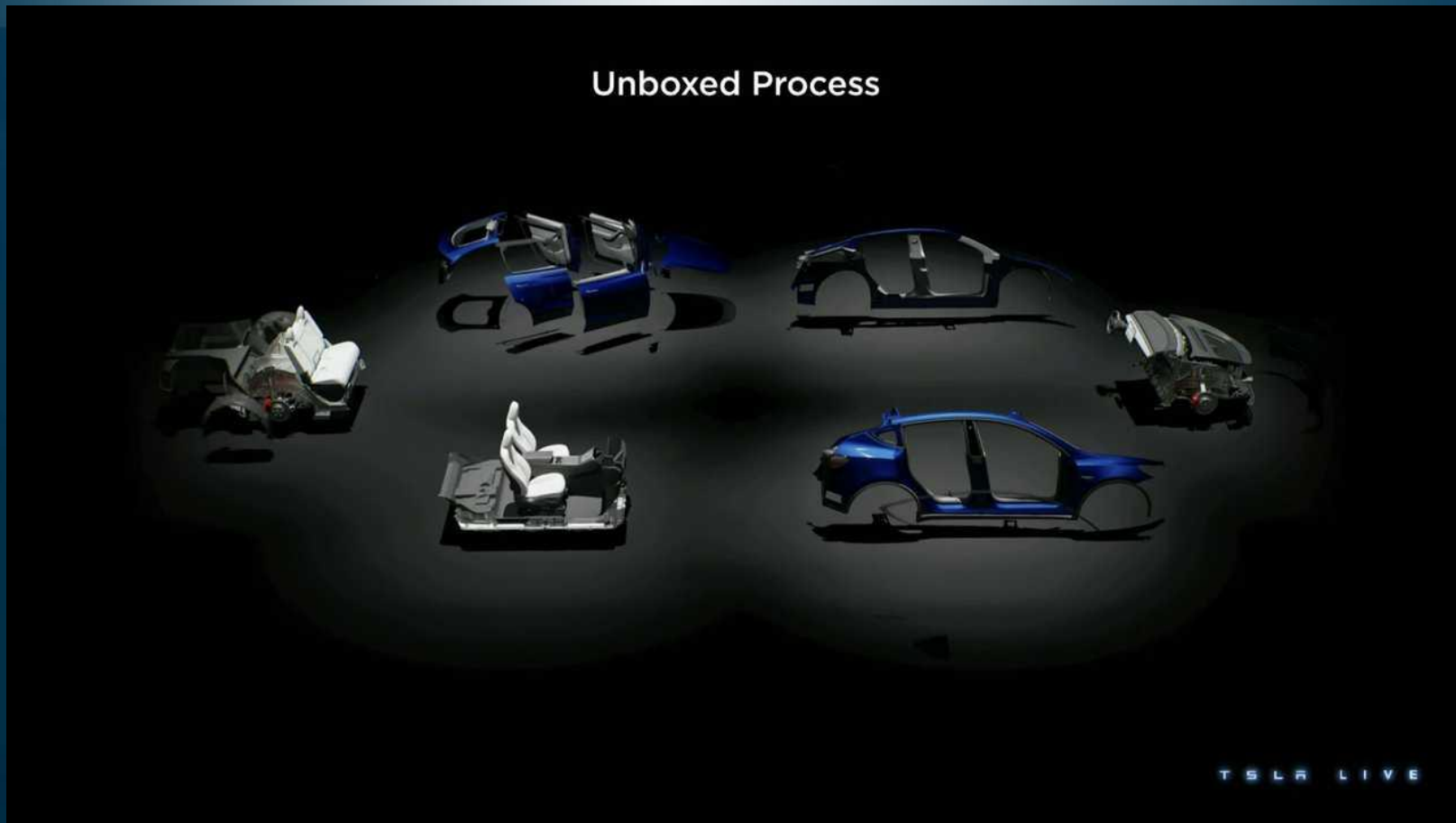

Radical Approach To Manufacturing



The Old Computing Mishmash

Conventional Architecture

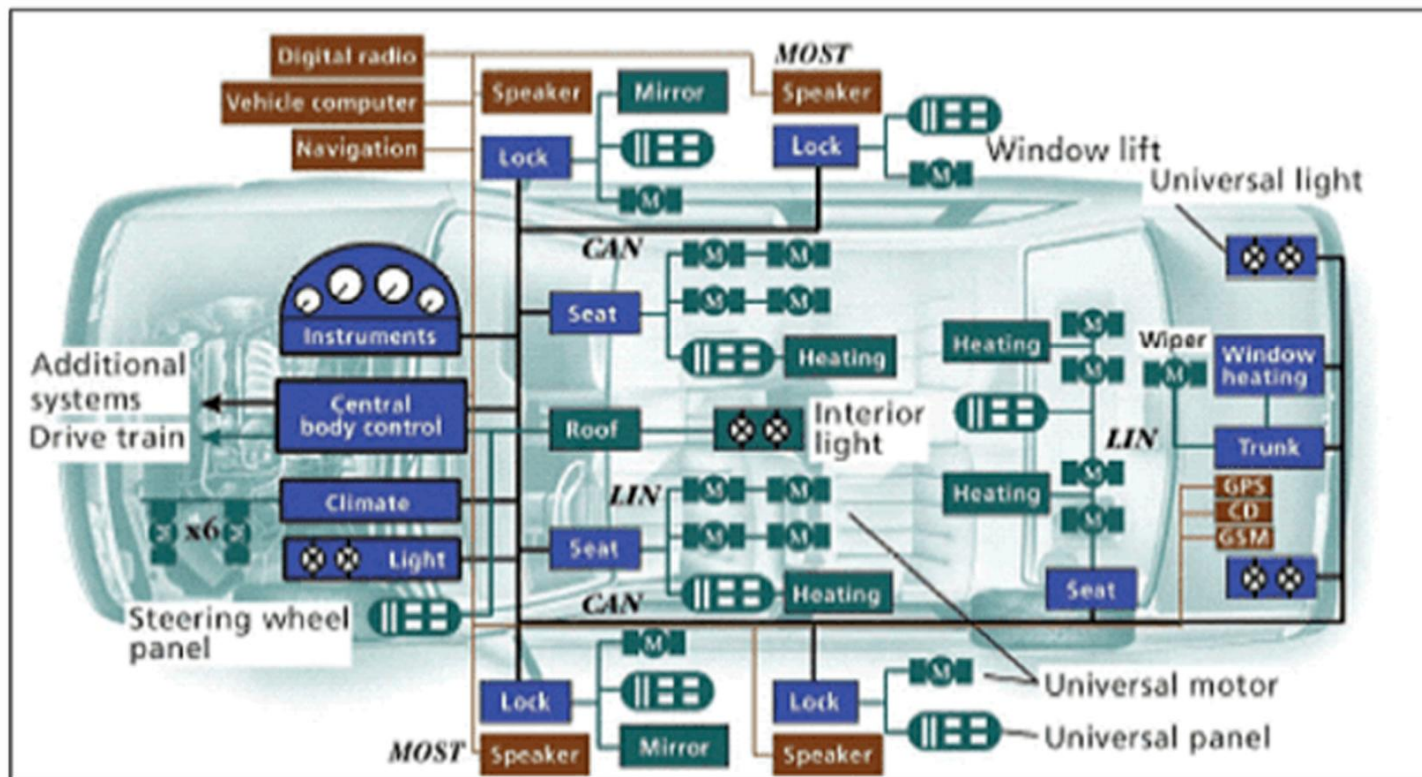

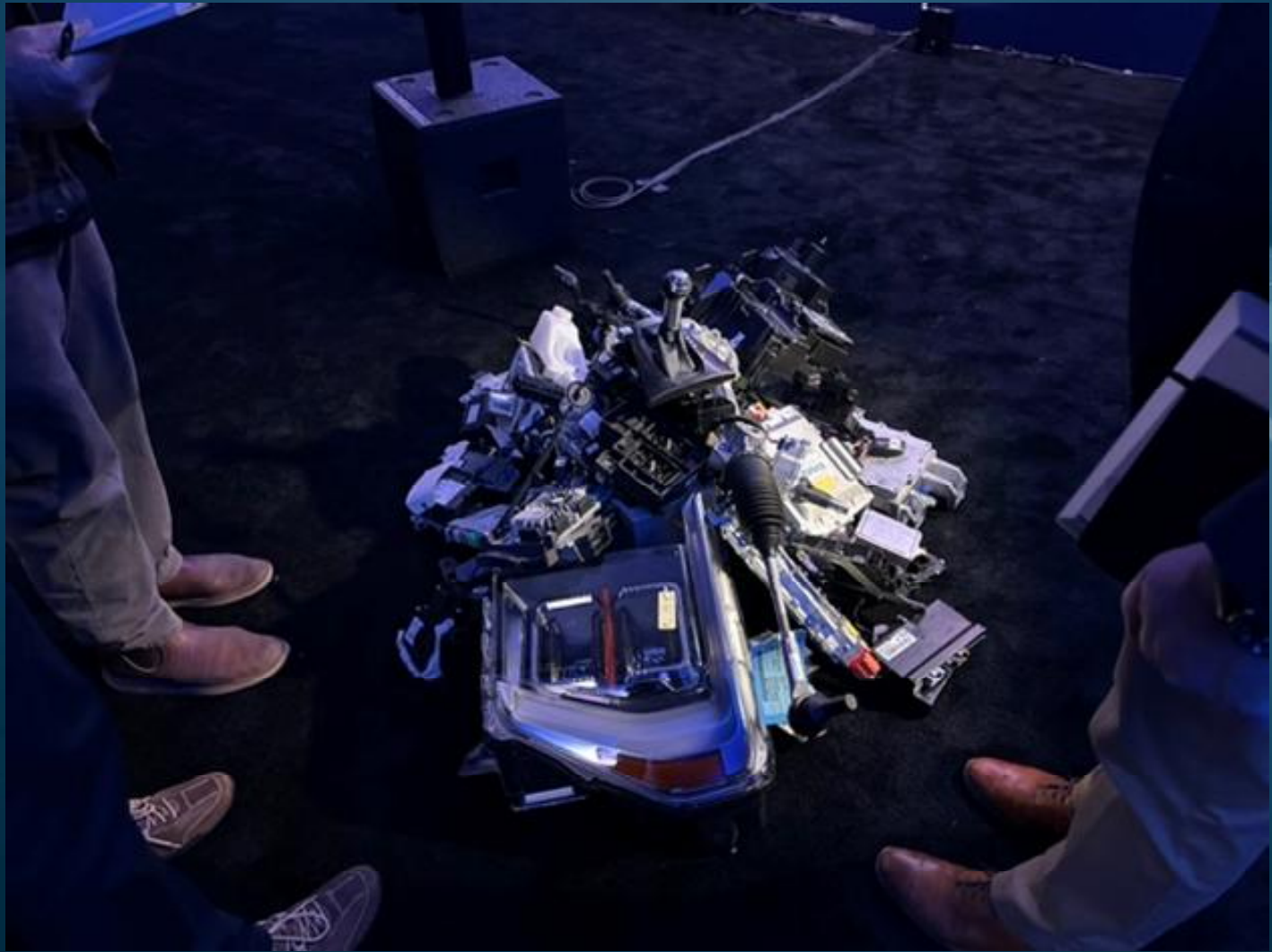

RE-CAP

- Most transformative time in auto industry since early 1900s
- Auto market has stopped growing in mature markets
- Some OEMs shrinking with inflation adjusted revenue & profits
- Raising prices, pressuring suppliers, de-contenting not the answer
- The only solution is to design cost out

AUTOLINE

www.Autoline.tv